

Modeling of Deflagration and Explosion coupled with the Structural Response

K. R. Anil Kumar¹, T. C. Arun Murthy, K. Suresh, P. Pillai, and A. Tripathi
Transoft International, Le Charles Michel,
7, Boulevard de la Libération, F-93200, SAINT-DENIS,
FRANCE

Abstract

A general-purpose code for the reactive fluid flow analysis, structural dynamics, and fluid-structure mechanical/thermal interaction, Fluidyn-EXPLODE, has been developed. In this model the reactive fluid flow is modeled by solving the 3D conservation equations for the momentum, energy, and species using finite volume method and the nonlinear transient stress calculations are performed by finite element method. The coupling between the fluid and the structure is done by exchanging the boundary condition data continuously at each time step. The fluid mesh is modified according to the instantaneous structural displacement. Using this model the detonation and deflagration of a mixture of hydrogen and oxygen in a confined volume are simulated for (a) a non-deforming structure, and (b) deforming structure. In the former case the temporal variations of pressure at five monitor points in the domain are compared with the experimental measurements. Results obtained with the deforming structure shows that in certain conditions the pressure wave propagation is significantly affected by the structural response.

¹ Corresponding author; e-mail: support@fluidyn.com

Introduction

Operation of most of the industrial and propulsion energy conversion systems involve deflagration of chemically reacting mixtures. The structures forming these systems can be subjected to considerable overpressures generated by deflagrations or detonations. Hence, the knowledge of the generation and propagation of the pressure waves in these processes and the response of the surrounding structures to them is very important in designing the power production systems. The aim of this paper is to demonstrate the ability of a CFD based Fluid Structure Interaction code (Fluidyn-EXPLODE) to simulate deflagration and/or detonation of reactive mixtures and the response of the encompassing structures to the pressure waves thus generated. This paper presents some of the results of the numerical simulations of the deflagration and detonation of the mixtures of hydrogen and oxygen inside a fully confined volume. It also deals with the effect of the structural deformation on the propagation of the pressure waves inside the volume.

Next section briefly describes the computational model used. Then the physical problem considered in this work is explained followed by a description of the geometric model, boundary and initial conditions, and the material properties used. Finally the results in the form of temporal variation of pressure at different monitor points are reported.

Computational Model

This section gives a brief description of the computational model used. Fluidyn-EXPLODE, a general-purpose code for the reactive fluid flow analysis, structural dynamics, and fluid-structure mechanical/thermal interaction, has been developed and is being used in the present study. The overpressures in the fluid, due to deflagration and/or detonation, are calculated by solving the conservation equations for the mass, momentum, energy, and species in a 3-dimensional

framework using the finite volume method. The computational model incorporates a wide range of deflagration, detonation and/or turbulence models and can handle multiple-species, multi-step chemical reaction schemes.

The response of the structures, which surrounds and interacts with the gaseous media and thus subjected to the transient overpressures, is obtained through a nonlinear transient stress analysis using the finite element method. In the coupled analysis for the fluid-structure interaction, boundary condition data is exchanged between the fluid and structure continuously. Pressure is applied to the structure as a force boundary condition, while the deforming structure influences the fluid flow as a moving boundary. Following any structural displacement the fluid domain is re-meshed to account for the change in the shape and size of the domain. The weak coupling offers great flexibility in deploying diverse numerical techniques for fluid flow analysis and structural stress analysis.

Physical Problem

In this study we used a benchmark experiment, performed by Sochet et al [1], on the deflagration and detonation of a mixture of hydrogen and oxygen in a confined volume as the physical problem. These measurements were previously used by Beccantini et al [2] to compare their numerical results on detonation.

Figure 1 shows the problem domain [1]. It comprises a prismatic box, which contains a hemispherical soap bubble confining a mixture of hydrogen and oxygen at the center of the bottom surface. However, in the present simulation, due to the symmetry of the system, only one fourth of the domain (see Figure 1) is considered. In the experiments, the reactive mixture was ignited either by a spark plug, which gives rise to a deflagration, or with an exploded wire, which leads to a detonation. In the computational study, the different ignition mechanisms were

modeled by varying the ignition energy and the rate of ignition energy release. Chemical reaction in the H₂–O₂ mixture is assumed to take place through a single-step global reaction of the form

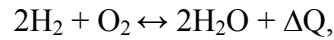

where, ΔQ is the heat released due to the reaction. Rate of change of mass of different species are computed using the equations of the Arrhenius form similar to that used by Beccantini et al [2]. However, in the present case an overall reverse reaction was also introduced to approximate the endothermic dissociation reactions taking place at temperatures higher than 3000 K (The developed CFD model is general and can incorporate many reactions and the species. A study using a multi-step mechanism for the H₂–O₂ system is in progress). In the present study, we selected two sets of experimental data for comparison with the computational results: one for detonation and another for deflagration. Both these data correspond to the hemispherical bubble with a radius of 0.05 m.

For the purpose of conducting the fluid-structure interaction study, the outer shell of the box is assumed to be made of steel plates with a uniform thickness of 5 mm. However, the actual experiment was conducted within a thick wooden box so that there was no deformation. In the present study a thinner for the structure was selected to demonstrate the deformation when subjected to the pressure wave. It is also fixed at the bottom face, i.e. the velocity of the bottom face is zero, to prevent the overall displacement of the structure due to the forces generated.

Geometric Model, Boundary and Initial Conditions, and Properties

The hemispherical bubble of reactive gases is located at (0,0,0), which is at the center of the bottom face. In the present case computations were done using cells of uniform size (0.005 m ×

0.005 m × 0.005 m) throughout the domain. No-slip conditions for velocity with zero flux for scalars are used at the walls. Also, the walls are assumed to be adiabatic. Initially the whole domain is at a pressure of 1.01325×10^5 Pa and a temperature of 300 K. In the case of detonation, the initial composition of the reacting mixture is given by $\phi = 1$, where ϕ is the ratio of the number of moles of hydrogen to the number of moles of oxygen in the stoichiometric mixture. For deflagration ϕ is equal to 1.25.

The fluid properties used are: kinematic viscosity of the mixture = 1.89×10^{-5} m²/s, Prandtl number of the mixture = 0.72, mass diffusivity of H₂ = 12.6×10^{-5} m²/s, and mass diffusivity of H₂O = 2.63×10^{-5} m²/s. Specific heats for all the species are calculated from the enthalpy values given in JANNAF tables.

The structural properties of the steel used are: yield strength = 2.1×10^{11} Pa, Poisson's ratio = 0.3, density = 7850 kg/m³, and tensile strength = 1.8×10^9 Pa.

Results

Pressure wave propagation with non-deforming structure

This section presents temporal evolution of pressure in the domain obtained in two simulations: (1) when the ignition energy is high enough for the initial deflagration to accelerate to an explosion, and (2) with low ignition energy, when the entire reactive mixture is burned in a deflagration mode. For both the cases the fluid-structure interaction is neglected, i.e., the structure is assumed to be non-deforming or absorbing energy from the incident pressure waves. In the first simulation the high ignition energy leads to the formation of a high-pressure (of the order of 10 bar) reaction wave front. In this case the reactive mixture is consumed completely in

a very short time ($< 1.0 \times 10^{-4}$ s). This high-pressure wave then propagates through the chemically inert air and gets reflected from the walls. Figure 2 shows the temporal evolution of the pressure recorded at five monitor points and are compared with the experimental measurements by Sochet et.al. [1]. The coordinates (in m) of these monitor points are: P0(-0.125,0,0); P7(-0.19,0.045,0.2); P11(-0.25,0.16,0); P10(0,0.3,0); P1(-0.19,0.255,0.2), with respect to the origin located at the center of the spherical bubble. At all the points the number of peaks and their arrival times compare well with the measured values for most of the duration of the simulation.

However, when ignition energy is low the deflagration generated relatively weak pressure waves, which propagated ahead of the deflagration front. Figure 3 shows the temporal evolution of the pressure recorded at different points in the domain due to the propagation of such a pressure wave. It is found that the predicted frequencies are matching very well with the experimental measurements. However, the peak pressures are much lower than the measured values. Also, there is a delay of about 0.5 ms in the arrival of the first peak (in Figure 3 the computational results are shifted to the right by a uniform duration). A possible reason for these could be the improper values of the ignition parameters, because ignition process is known to affect the nature of deflagration to a greater extent than it does with the detonation or explosion.

Pressure wave propagation with deforming structure

In this case the structure is assumed to be of finite strength and is deforming when subjected to incident pressure waves. Figure 4 shows the temporal variation of pressure at the four monitor points. It is found that there are two effects of a deforming structure: (1) to decrease the amplitude of the pressure waves and (2) to change the frequency and arrival time of the waves. The first effect may be attributed to the fact that the structure absorbs some of the energy from

the pressure waves instead of reflecting it back completely. However, it is also observed that at all the monitor points the pressure wave takes less time to arrive compared to the non-deforming structure. This could be due to the acceleration of the pressure wave induced by the expansion of the confined volume due to the outward deformation of the outer shell. Further investigation of this is currently being done.

Figure 5 shows the deformation of the structure (magnified by 20 times) at different instants during the simulation. At 0.5 ms the maximum displacement in the x , y , and z directions is 0.4 mm. This is the deformation due to the initial pressure difference between the volume and the outside. At 1 ms these values are 1.2 mm, 1.9 mm, and 1.5 mm, and at 1.5 ms these are 1.11 mm, 3.5 mm and 2.3 mm respectively. It is found that the displacements oscillate due to the successive incidence of high and low pressure due to the wave motion.

Conclusion

A general-purpose code for the reactive fluid flow analysis, structural dynamics, and fluid-structure mechanical/thermal interaction, Fluidyn-EXPLODE, has been developed. The CFD model for the reacting flows was used to simulate deflagration and detonation of H_2 - O_2 mixtures and the results compared with the experimental measurements. For detonation the comparison was good. In the case of deflagration the frequency of the pressure waves generated was predicted correctly. However, there are significant differences in the magnitude and total propagation time. This could be due to the difference in the magnitude and the rate of addition of the ignition energy.

A typical fluid-structure interaction problem has been simulated by allowing the outer shell of the structure to deform under pressure differences. It is found that, in the case considered the

structural deformation significantly affected the qualitative and quantitative behavior of the pressure wave propagation inside the confined volume.

References

1. Sochet, I., Renard, J., Trimoulet, A., and Desrosier, C., Etude Expérimentale des Interactions Onde de Choc et Structures Lors d'une Explosion en Espace Confiné, Technical Report, LEES, Bourges, 1997.
2. Beccantini, A., Paillère, H., Morel, R., and Dabbene, F., Multi-dimensional Simulation of Hydrogen Detonations, 17th International Colloquium on the Dynamics of Explosions and Reactive Systems, July 25-30, 1999, Heidelberg, Germany.

List of Figure Captions

Figure 1. Problem domain.

Figure 2: Temporal evolution of pressure at various points: 1- experiment, and 2 – computations.

Figure 3: Temporal evolution of pressure at various points: 1 –experiment, and 2 –computations.

Figure 4: Temporal evolution of pressure at various points: 1- with structural deformation, and 2 – with rigid structure.

Figure 5: Shape of the frame (magnified by 20 times) at different instants: (a) 0.0 ms, (b) 0.5 ms, (c) 1.0 ms, and (d) 1.5 ms

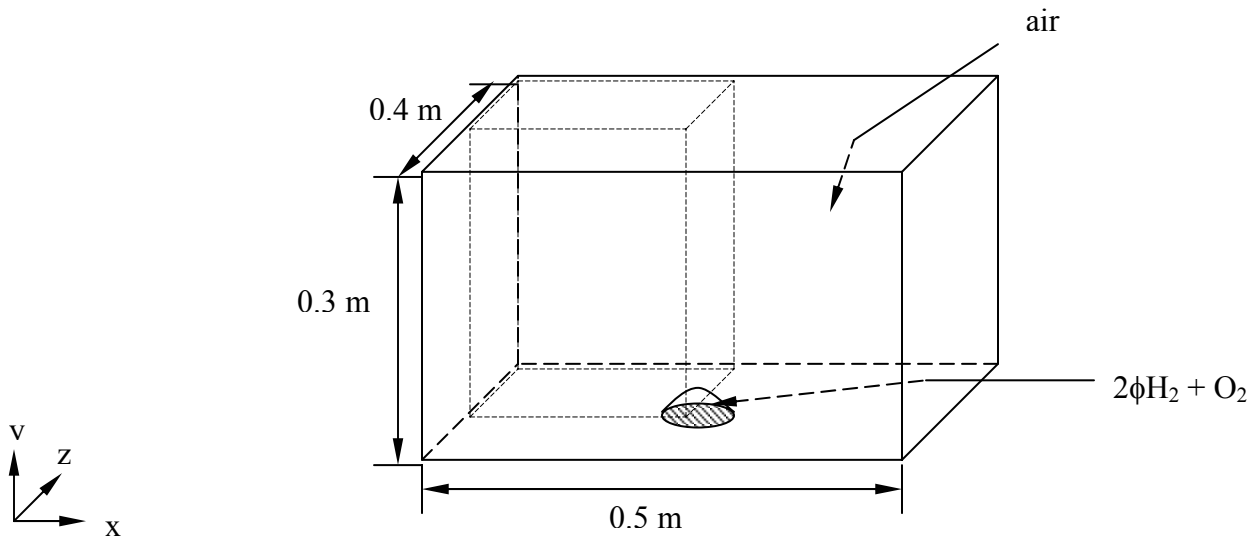

Figure 1. Problem domain

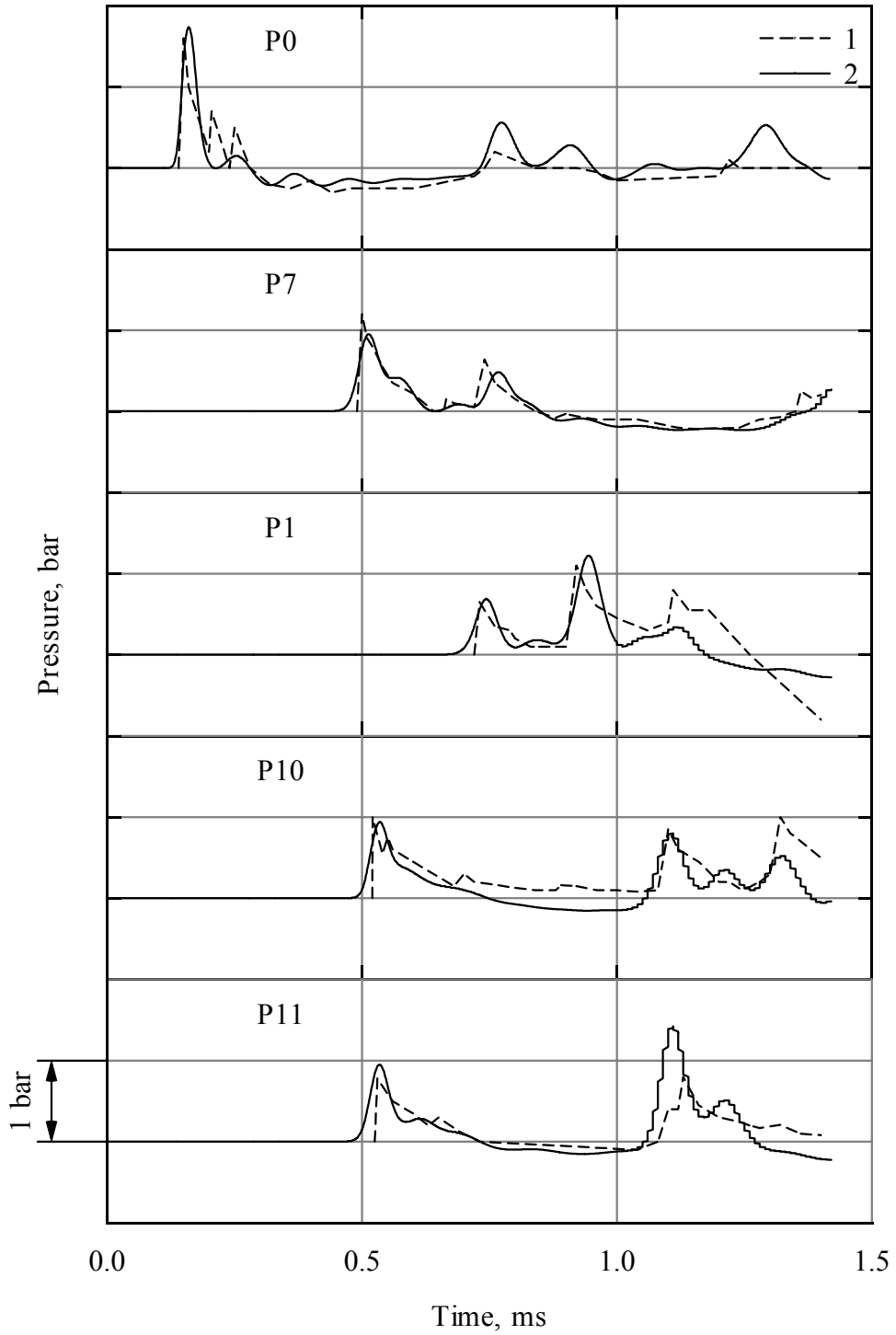

Figure 2: Temporal evolution of pressure at various points:
1- experiment, and 2 – computed

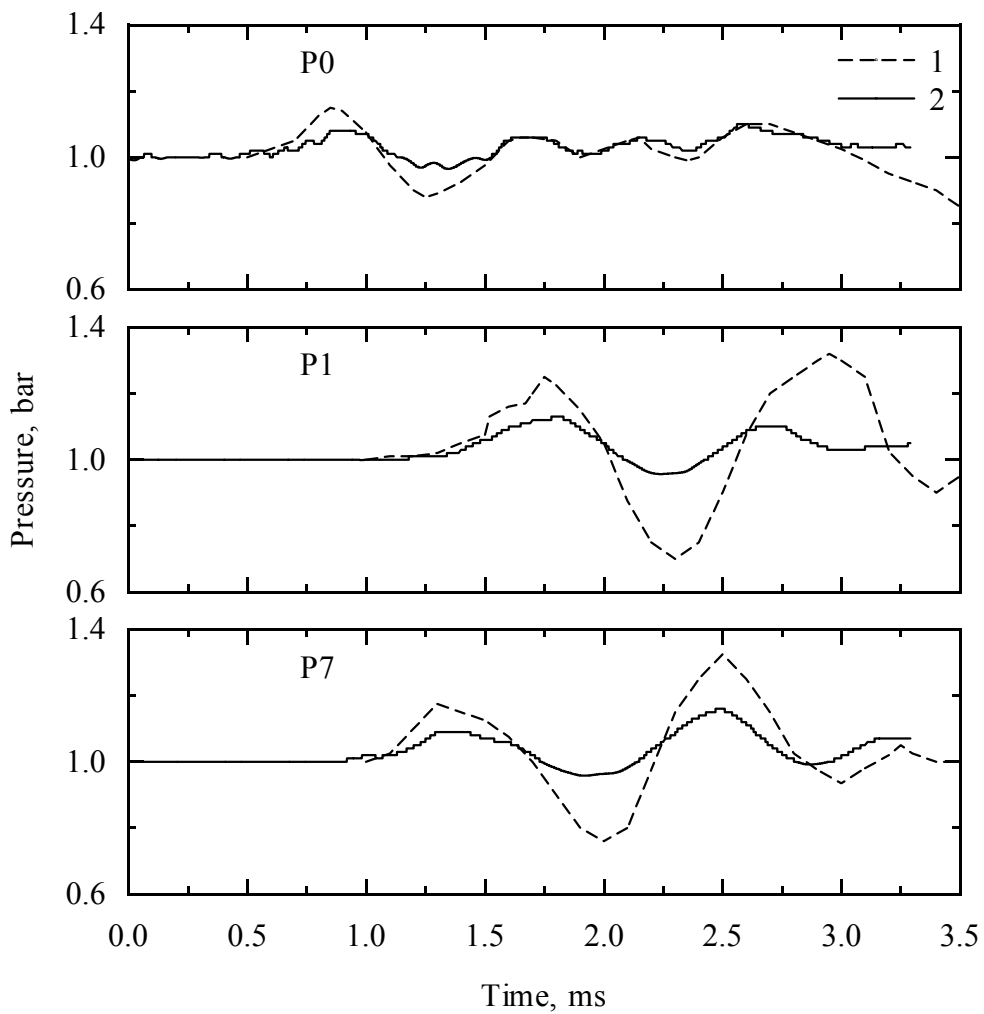

Figure 3: Temporal evolution of pressure at various points:
1 – experiment, and 2 – computed

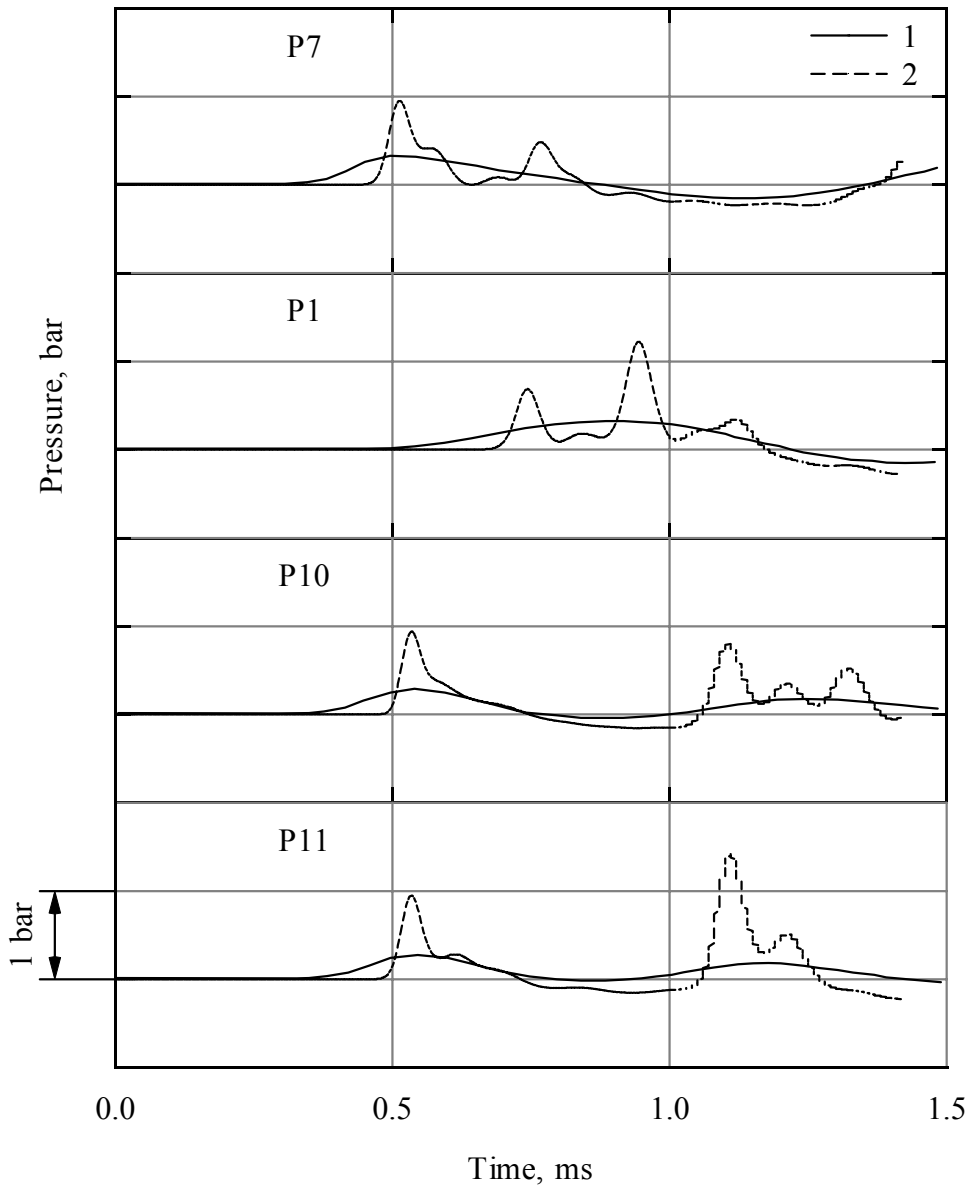
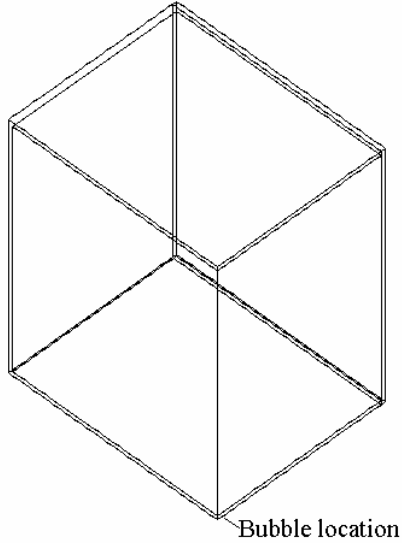
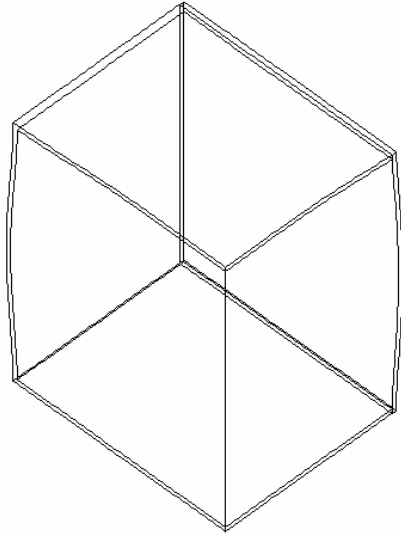

Figure 4: Temporal evolution of pressure at various points:
 1- with structural deformation, and 2 – with rigid structure



(a)



(b)

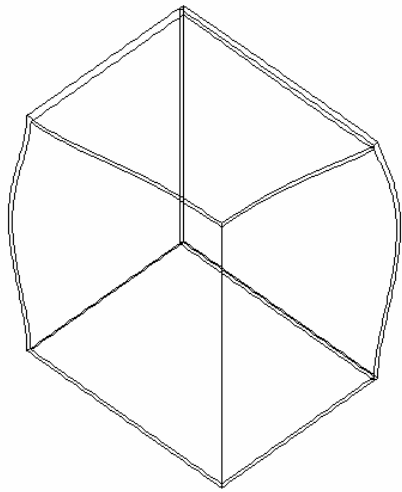

(c)

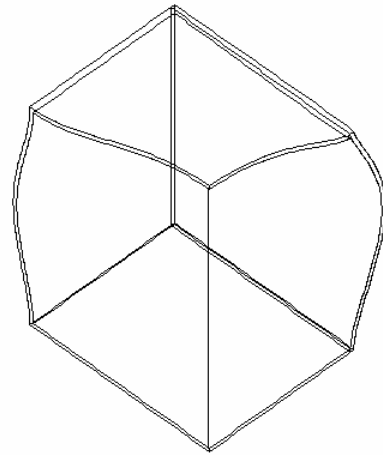

(d)

Figure 5: Shape of the frame (magnified by 20 times) at different instants:
(a) 0.0 ms, (b) 0.5 ms, (c) 1.0 ms, and (d) 1.5 ms